

**Part No. 12854**  
**Rear Bumper Cover, O.E. Design**  
**1987-93 Mustang LX**

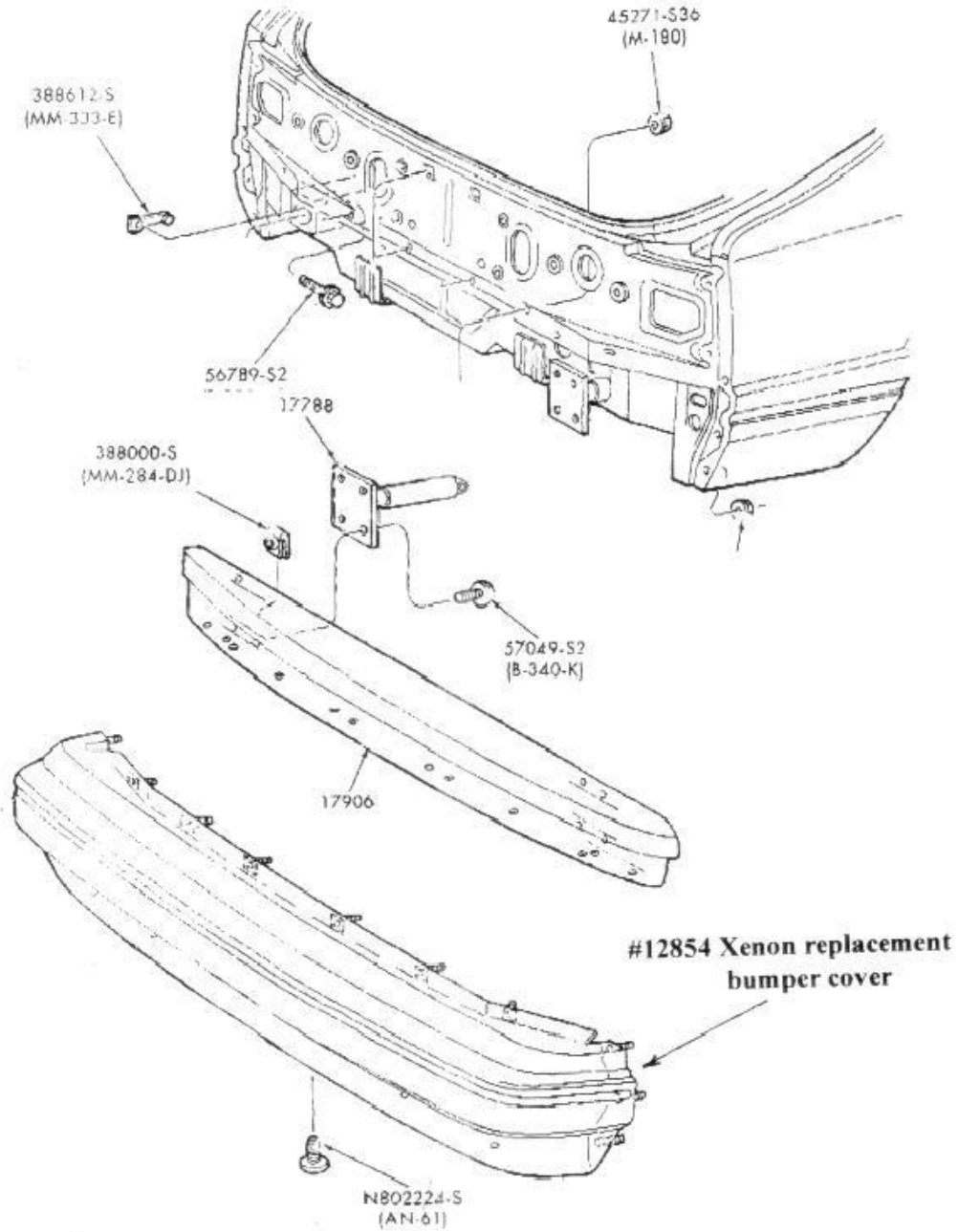

**PLEASE READ INSTRUCTIONS THOROUGHLY BEFORE PROCEEDING**

We have provided complete instructions and hardware; the list of these items is listed on the last page of the instructions (if applicable).

- **Please verify that you received the correct part(s). All part numbers are embossed on the inside of the urethane component(s).**

Tools and general materials required: Acetone or MEK, Burgundy Scotchbrite pad, cleaning cloths, Various hand tools

**THERE ARE FOUR PHASES TO MOST INSTALLATIONS:**

1. Removal of factory parts and then TEST FIT the reproduction product
2. Preparation of the parts for paint and painting
3. Installation of the part

**PHASE 1) REMOVAL & TEST FIT**

- **REMOVAL: Remove the factory rear bumper skin and save ALL hardware.** Note how the factory hardware installs onto the factory bumper cover. Our replacement cover uses the factory hardware and installs in the same manner as the factory part.
- **TEST FIT the parts to verify excellent fit**

**DO NOT PREP, DRILL, OR PAINT THE PARTS UNTIL TEST FITTING IS COMPLETE!**

**NOTE:**

Urethane parts might seem to be slightly distorted upon test fit. If so, place them in the sun topside down (if a warm day) or in a warm area, approximately 70-80 degrees F, for 2-3 hours and it will return to its original shape and become more flexible.

**PHASE 2) PREPARATION OF URETHANE PART (S) FOR PAINTING:**

This process is following an approved Sherwin Williams procedure and materials. Consult your paint supplier for equivalent materials and / or procedures.

- WASH the paintable surfaces with a heavy duty detergent degreaser i.e....Castrol purple stuff, Palmolive liquid dish soap, red hot, and USP90 scuff gel, using a gray scuff pad until the part is dull and then rinse thoroughly.
- SAND across item with 400 grit or finer paper and check for imperfections. Repair as needed.
- RE-WASH with heavy detergent degreaser and USP90 scuff gel or Palmolive liquid dish soap using gray scuff pad to remove any residue. Rinse thoroughly and wipe dry with a lint free towel.
- WIPE item down using SC159 plastic and anti-static cleaner with lint free towel.
- SPRAY item with UPO7227 plastic adhesion promoter.
- SPRAY item with P30 sealer base coat then clear coat.
- **DO NOT oven bake our parts above 100 degrees F.** They should be well supported during any heat cycle to avoid the flexible part from warping.

**PHASE 3: INSTALLATION OF THE PART (Perform in a warm area of 70 degrees or greater)**

- **Install the factory “plates” across the inside of the top flange and at both bumper flanges at the ends of the bumper. Again, this factory hardware installs on our part just like on the factory OE bumper cover.**
- **After aligning the bumper cover secure the part by screwing on the nuts onto the factory hardware studs. Do not over-tighten.**

**PART NUMBER (S):**

**12854 – Rear bumper replacement cover, LX model**

**HARDWARE PROVIDED:**

**No hardware provided- use the factory hardware that comes from the original rear factory cover. If your original hardware is damaged, contact your local Ford Dealers Parts Department for the correct hardware for your vehicle.**

**DATE:**

**July 14, 2009**

**AMERICAN BEST CAR PARTS**

**XENON**

**2891 VIA MARTENS**

**ANAHEIM CA 92806**

**714-632-1709 Phone**

**[www.teamxenon.com](http://www.teamxenon.com)**